

# MEC 800 SPECIAL

- Oil-hydraulic ram operator
- For swinging gates
- Weatherproof

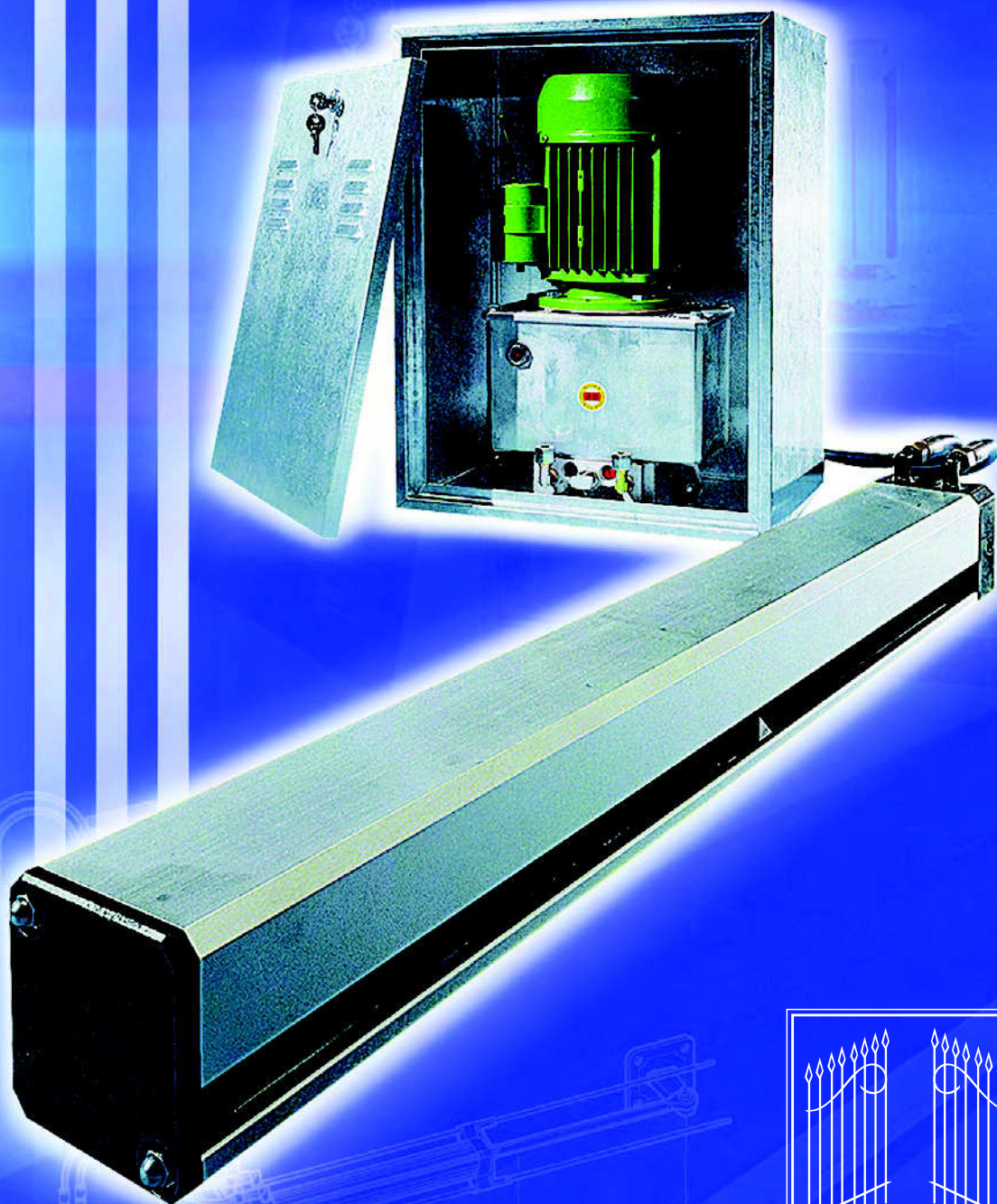

GB

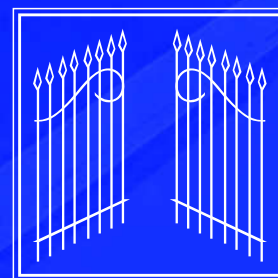

**FADINI**<sup>®</sup>  
the gate opener

## Swinging gates weatherproof oil-hydraulic ram



The system **MEC 800 Special** is made up of a ram and a separate oil-hydraulic motor pump unit. Designed for heavy duty, automatic operations of big swinging gates of significant weight. Being oil-hydraulic, ram power is fully under control of the safety, anti-crush valve device, and reliability of operations is guaranteed. Among the advantages offered by "MEC 800 Special" there is the possibility of fitting a second ram to get a higher power rating when particularly big gates are involved, total safety control is always guaranteed. The ram operators are available in two options, the 280 mm stroke up to three metre gate width, each gate; and the 400 mm stroke for gate leaves that are wider than three metres. A high reliability standard is ensured by the motor pump unit which makes up the system. This unit is fitted with a 0,5 HP motor, air-cooled, equipped with a capacious oil reservoir, hydraulic lobe pump and adjustable safety pressure valves to control the traction/pushing power developed by the system. A non air-cooled option is available on request; this model is made up of an oil reservoir made of extruded aluminium which houses the lobe pump, electric motor, and safety pressure valve block. A door locks up the unit for maximum security. This option is recommended for applications involving not particularly heavy gates with a limited

number of operations a day. Both types are fitted with a "lobe" pump, in an oil reservoir, which controls oil displacement through a valve design system. Depending on the motor revolving direction, the gate is driven open or closed. The ram is very strong as it is made of high quality materials to ensure maximum reliability: the shaft is made of chromium-plated steel and the whole unit is protected by a cover made of anodized extruded aluminium.

The system is to be properly piped. Copper pipes are required to connect the motor pump unit to the connection block; and two high

### HEAVY DUTY

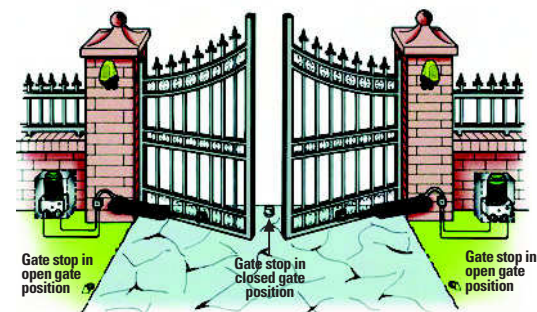

Open and close operations are by keyswitch, remote control or digital keypad

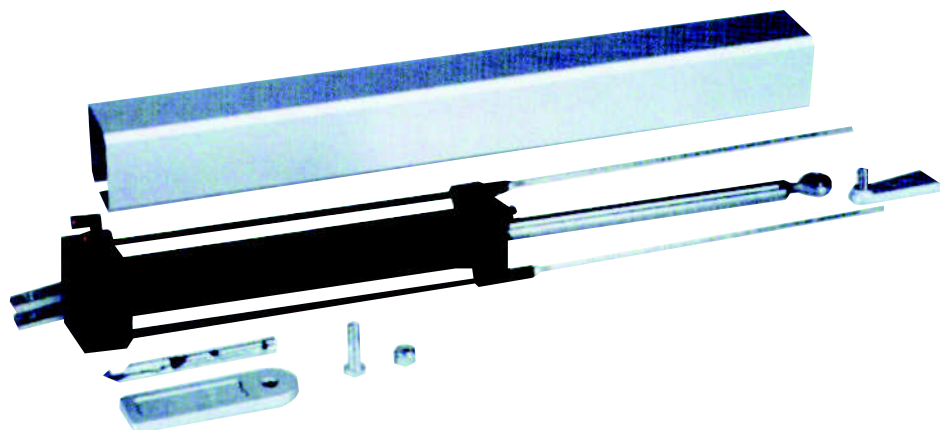

pressure hoses from the 4 way block to "MEC 800" ram in order to safely allow rotation of the gate. An enclosure made of galvanized metal can be provided to house the "motor pump unit". The door is fitted with a lock to prevent misuse. The system can work through an electronic control panel to which all the required accessories can be connected to operate the equipment such as access control devices, keyswitch etc., or safety accessories such as photocells, flashing lamp, and rubber edges either pneumatic or mechanically operated by wire switch. The control panel is also designed to take the radio remote control receiver. Now even more reliable thanks to a "personalized" transmitter. This operator is the result of thirty years' experience in gate automation systems and is able to guarantee quality and reliability that are most important when very large gates are involved, in full respect of the existing safety regulations. Designed, produced and tested by Meccanica Fadini.

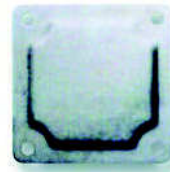

Rear fixing  
reinforcement plate

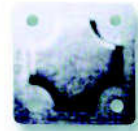

Front fixing  
reinforcement plate

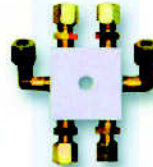

**7038** - 6 way pipe  
connecting block



**7013** - 4 way pipe  
connecting block



**7019** - flow rate regulator  
with connectors

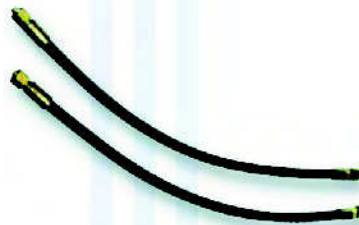

**7018** - 0.5 m hoses



**707** - copper pipe ø 8, 4 metres, Kg 1



Double mount where 2 rams are  
required to open/close a single gate



**7022** - motor pump unit  
MEC 700/80 VENTIL two-way locking



**7016** - large enclosure to suit the hydraulic  
motor pump type MEC 700/80 VENTIL



Single mount where 1 ram is  
required to open/close one gate only



**701** - motor pump unit type DRIVE 700 ESTRU  
complete with valves, pipe joints,  
manual release, door with lock



**7070** - enclosure to suit DRIVE 700 ESTRU  
motor pump. Zinc-coated, door with lock

# MEC 800 SPECIAL GATE OPENER

## Technical specifications

### MOTOR-PUMP UNIT - DRIVE 700 ESTRU

Pump flow rate - P3	0.85 l/min.
Average working pressure	1 MPa (10 bars)
Max. working pressure	3 MPa (30 bars)
Working temperature	-20°C +80°C
Type of hydraulic oil	A 15 FADINI by AGIP
Oil reservoir capacity	0.95 dm <sup>3</sup>
Static weight of motor pump	8 Kg
Protection standards	IP 673
Power output	0.24 KW (0.33 HP)
Supply voltage / Frequency	230 V - 50 Hz
Absorbed current	2 A
Absorbed power	400 W
Capacitor	12.5 µF
Motor Rotation Speed	1'350 r.p.m.
Intermittent Service	S 3

### MOTOR-PUMP UNIT - MEC 700/80 VENTIL

Power flow rate - P6	1.6 l/min.
Average working pressure	2 MPa (20 bars)
Max. working pressure	4 MPa (40 bars)
Working temperature	-25°C +80°C
Type of hydraulic oil	A 15 FADINI by AGIP
Oil reservoir capacity	2 dm <sup>3</sup>
Static weight of motor pump	10 Kg
Protection standards	IP 673
Power output	0.37 KW (0.5 HP)
Supply voltage / Frequency	230 V - 50 Hz
Absorbed current	2.4 A
Absorbed power	510 W
Capacitor	20 µF
Motor rotation speed	1'350 r.p.m.
Intermittent service	S 3

### Duty cycle MEC 700/80 VENTIL

.....28 sec. openign - 30 sec. dwell - 28 sec. closing
Time of one complete cycle.....86 s
No. of complete cycles: Open-Dwell-Close .....41/hour
No. of cycles a year (approx.) 8 hours a day.....122'000

### OIL-HYDRAULIC RAM MEC 800

Time of one stroke "out"	28 s
Working stroke	280 mm
Piston diametre	50 mm
Shaft diametre	22 mm
Max. pulling power open	390 Kg
Max. pushing power close	490 Kg
Weight of MEC 800 RAM OPERATOR	5.5 Kg
Overall dimensions (L x W x H)	840 x 85 x 110 mm
Protection standards	IP 673
Max. gate weight	2'000 Kg

### WARNINGS

- It is recommended to keep to the instructions here outlined. Check that the specifications on the motor sticker are compatible with your mains supply.
- Dispose properly of packaging materials such as cardboard, nylon, polystyrene etc. through specialized companies.
- Should the ram operator be removed, drain oil from ram into oil

Distributor's box

The manufacturers reserve the right to change the products without any previous notice



AUTOMATIC GATE MANUFACTURERS

Via Mantova, 177/A - 37053 Cerea (Verona) Italy - Tel. +39 0442 330422 r.a. - Fax +39 0442 331054 - e-mail: info@fadini.net - www.fadini.net

## Accessories



**ELPRO 13 CEI**  
single-phase control box



**PRIT 19**  
keyswitch



**PULIN 3**  
push buttons



**MIRI 4**  
flashing lamp



**BIRIO A8**  
rod aerial



**POLO 44**  
photocells



**ASTRO 43/1 R**  
radio receiver



**ASTRO 43/2 TR**  
transmitter

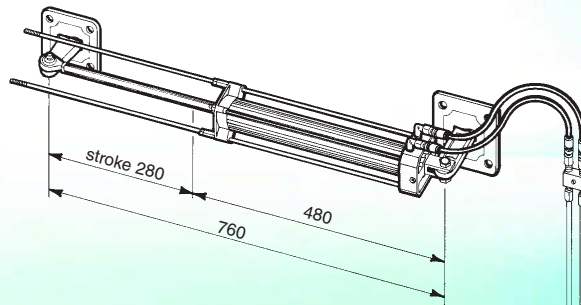

Oil-hydraulic operator MEC 800  
- 400 mm stroke. Same technical features  
- see technical specification table

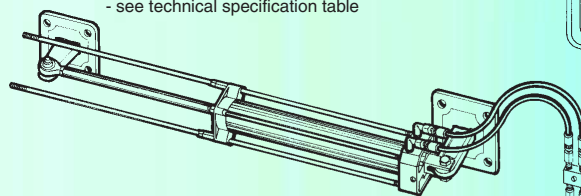

- AVAILABLE OPTIONS**
- No hydraulic locking.
  - Hydraulic locking.
  - With flow regulator.

Medium size Enclosure  
700 ESTRU

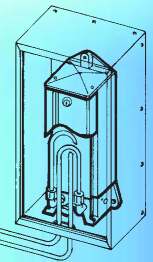

Large Enclosure to suit  
MEC 700/80 VENTIL

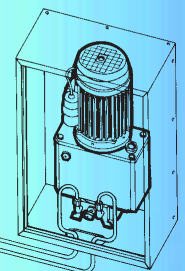

**EUROPEAN MARK  
CERTIFYING CONFORMITY  
TO THE ESSENTIAL  
REQUIREMENTS OF THE  
STANDARDS 98/37/EC**

- **DECLARATION OF CONFORMITY**
- **GENERAL WARNINGS**
- **EN 12445, EN 12453 STANDARDS**
- **CEI EN 60204-1 STANDARDS**
- **WARRANTY CERTIFICATE ON THE CUSTOMER'S REQUEST**

The "CE" mark certifies that the operator conforms to the essential requirements of the European Directive art. 10 EEC 73/23, in relation to the manufacturer's declaration for the supplied items, in compliance with the body of the regulations ISO 9000=UNI EN 29000. Automation in conformity to EN 12453, EN 12445 safety standards. The growth of MECCANICA FADINI has always been based on the development of guaranteed products thanks to our "TOTAL QUALITY CONTROL" system which ensures constant quality standards, updated knowledge of the European Standards and compliance with their requirements, in view of an ever increasing process of improvement.